

6

5

4

3

2

1

D

D

ITEM NO.	SW-File Name(File Name)	QTY.
1	Stick Vice PCB, block 2	1
2	Stick Vice PCB, block 4 soft jaws	2
3	Stick Vice PCB, rod	1
4	Stick Vice PCB, block 1	1
5	92981A103_ALLOY STEEL SHOULDER SCREW M5x20x10x10	2
6	Stick Vice PCB, block 3	1
7	91292A058_TYPE 18-8 SS SOCKET HEAD CAP SCREW M5x14mm	1
8	92005A118_METRIC PAN HEAD PHILLIPS MACHINE SCREW M3x8mm	4
9	96445A360_ROUND THUMB NUT W FLANGE M5x5mm	1
10	92605A110_NONMARRING FLAT POINT SET SCREW M4x5mm	1

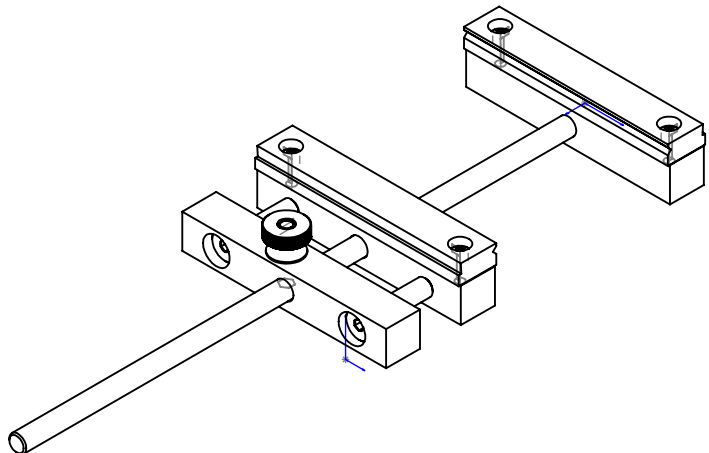

C

C

B

B

UNLESS OTHERWISE SPECIFIED: DIMENSIONS ARE IN MILLIMETERS SURFACE FINISH: TOLERANCES: LINEAR: ANGULAR:			FINISH:		DEBURR AND BREAK SHARP EDGES		DO NOT SCALE DRAWING		REVISION		
DRAWN R Bates			SIGNATURE		DATE		TITLE: <h1>BOM</h1>				
CHK'D							DWG NO. <h1>Stick Vice PCB</h1>				
APPVD											
MFG							SCALE:1:5				
Q.A											
					MATERIAL:		SHEET 1 OF 5				
					WEIGHT:						

A

A

6

5

4

3

2

1

6

5

4

3

2

1

D

D

C

C

B

B

A

A

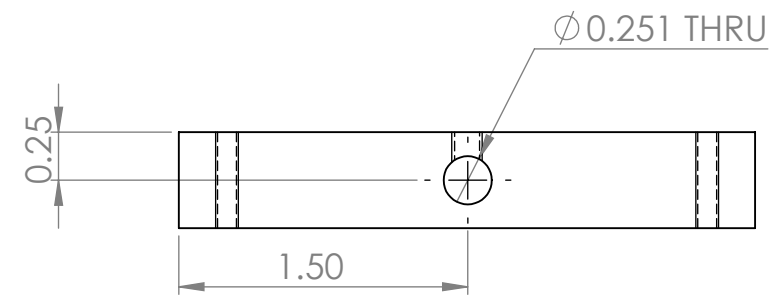
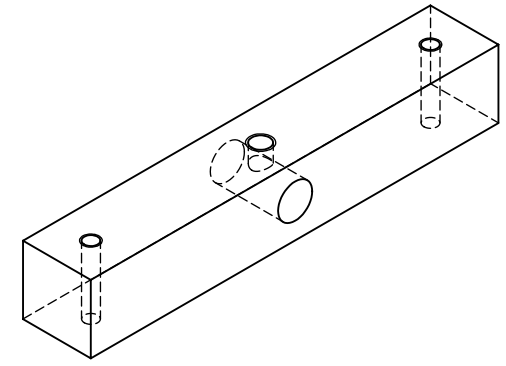
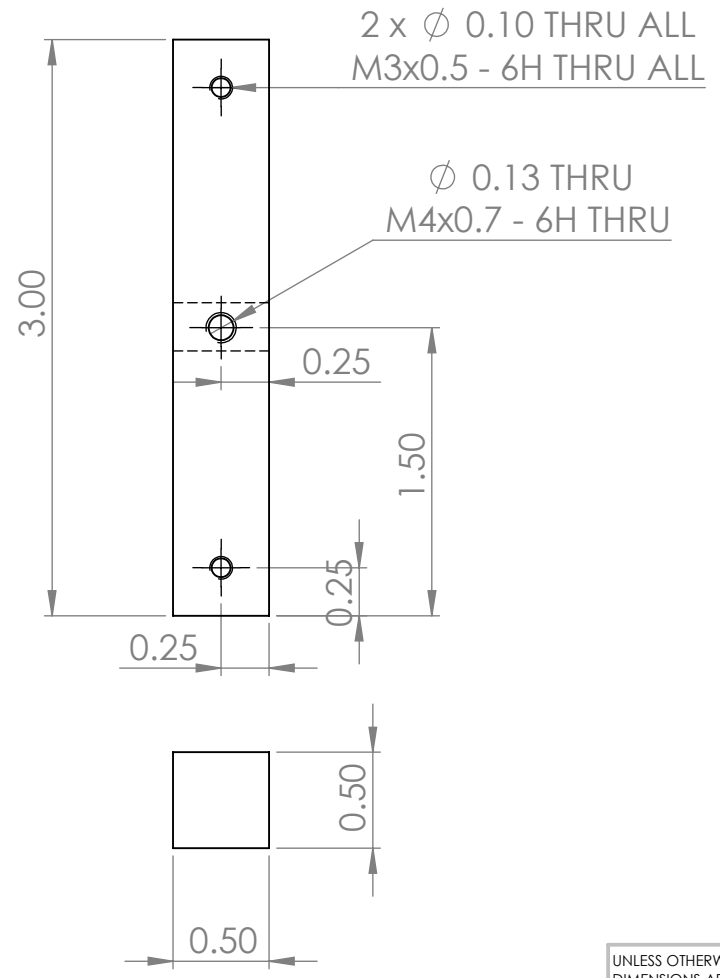

UNLESS OTHERWISE SPECIFIED: DIMENSIONS ARE IN MILLIMETERS SURFACE FINISH: TOLERANCES: LINEAR: ANGULAR:				FINISH:		DEBURR AND BREAK SHARP EDGES		DO NOT SCALE DRAWING		REVISION	
DRAWN R Bates				SIGNATURE		DATE		TITLE: Block 1			
CHK'D								DWG NO. Stick Vice PCB			
APPV'D											
MFG								SCALE:1:2			
Q.A											
						MATERIAL:		SHEET 2 OF 5			
						WEIGHT:					

6

5

4

3

2

1

6 5 4 3 2 1

D
C
B
A

D
C
B
A

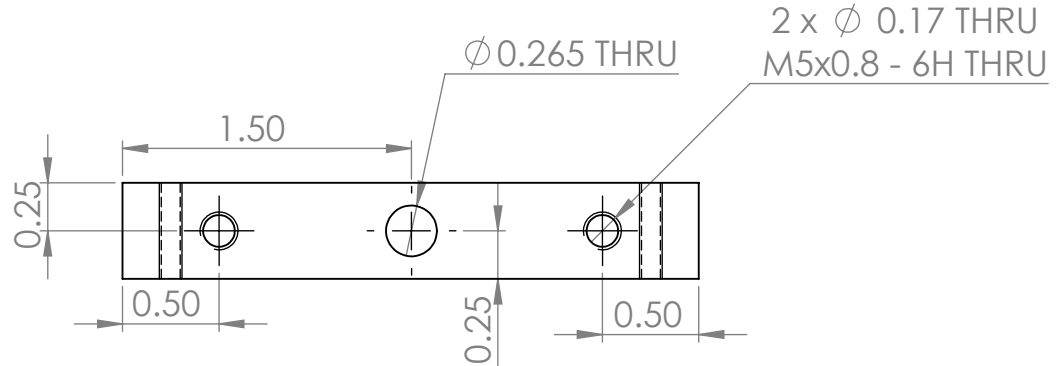
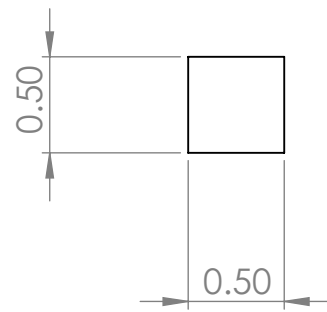
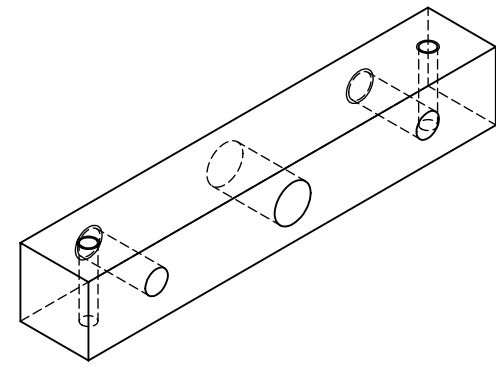
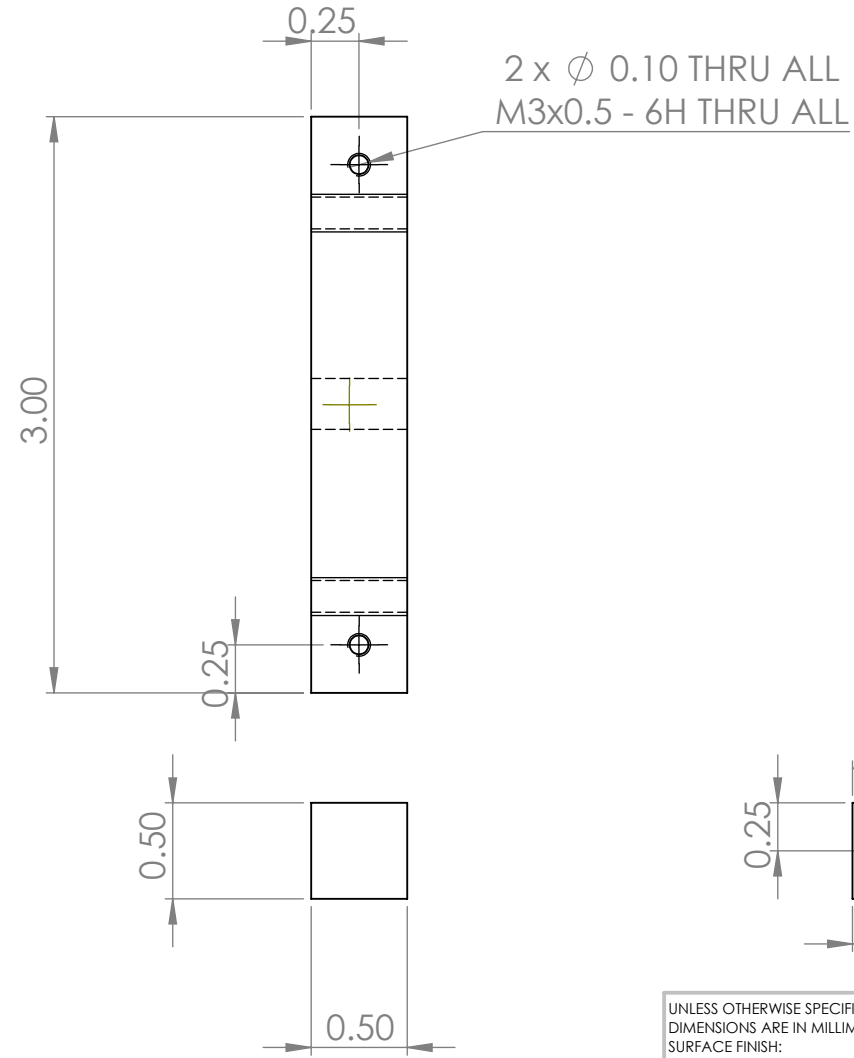

UNLESS OTHERWISE SPECIFIED: DIMENSIONS ARE IN MILLIMETERS SURFACE FINISH: TOLERANCES: LINEAR: ANGULAR:				FINISH:		DEBURR AND BREAK SHARP EDGES		DO NOT SCALE DRAWING		REVISION	
DRAWN R Bates				SIGNATURE		DATE		TITLE: Block 2			
CHK'D								DWG NO. Stick Vice PCB			
APPV'D											
MFG								SCALE:1:2			
Q.A											
						MATERIAL:		SHEET 3 OF 5			
						WEIGHT:					

6 5 4 3 2 1

6

5

4

3

2

1

D

D

C

C

B

B

A

A

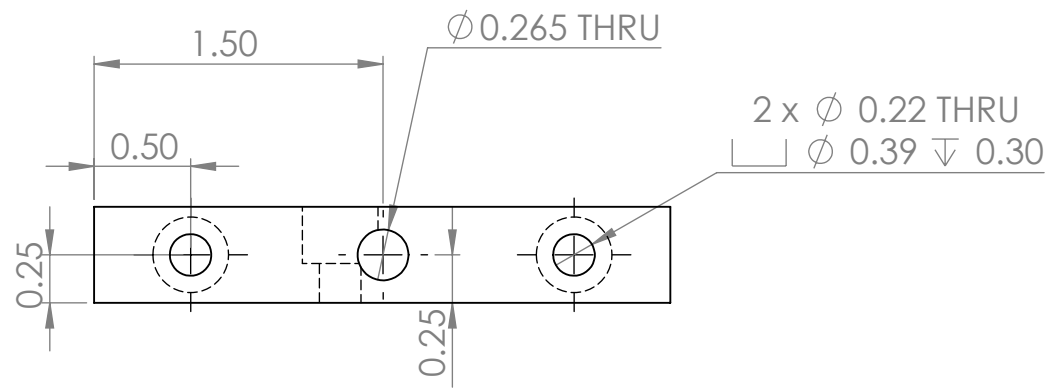
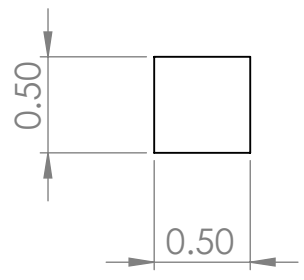
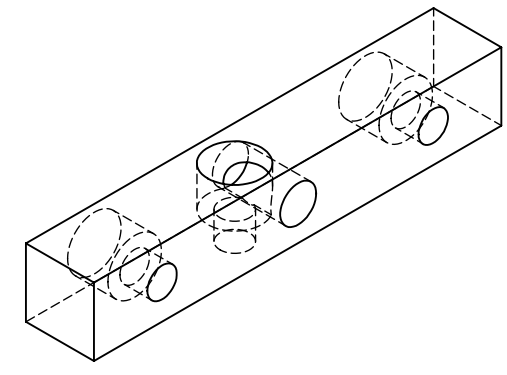
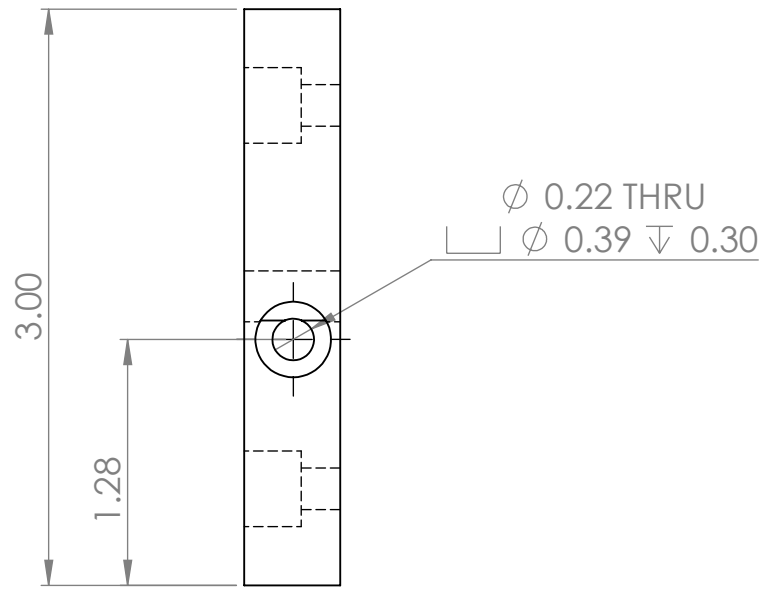

UNLESS OTHERWISE SPECIFIED: DIMENSIONS ARE IN MILLIMETERS SURFACE FINISH: TOLERANCES: LINEAR: ANGULAR:			FINISH:		DEBURR AND BREAK SHARP EDGES		DO NOT SCALE DRAWING		REVISION	
DRAWN R Bates			SIGNATURE		DATE		TITLE: Block 3			
CHK'D										
APPV'D										
MFG										
Q.A					MATERIAL:		DWG NO. Stick Vice PCB		A4	
					WEIGHT:		SCALE:1:2		SHEET 4 OF 5	

6

5

4

3

2

1

6

5

4

3

2

1

D

D

C

C

B

B

A

A

2 x ϕ 0.13 THRU ALL
 \square ϕ 0.26 ∇ 0.16

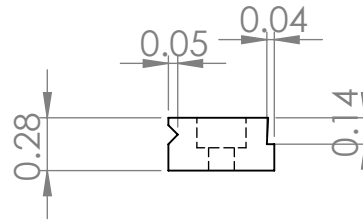
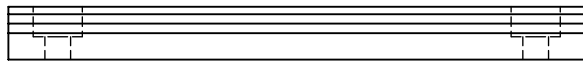
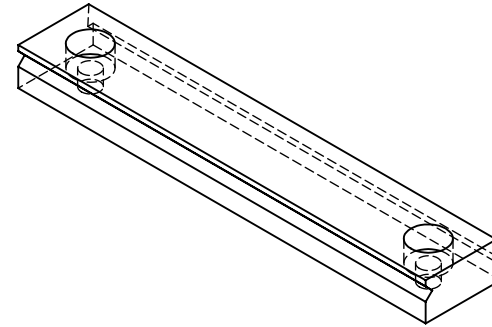
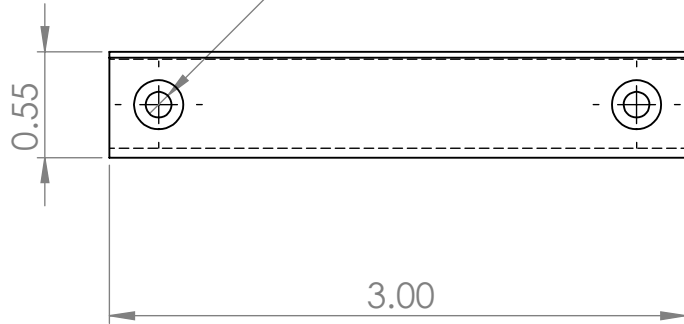

UNLESS OTHERWISE SPECIFIED: DIMENSIONS ARE IN MILLIMETERS SURFACE FINISH: TOLERANCES: LINEAR: ANGULAR:				FINISH:		DEBURR AND BREAK SHARP EDGES		DO NOT SCALE DRAWING		REVISION	
DRAWN R Bates				SIGNATURE		DATE		TITLE: <h1>Soft Jaws</h1>			
CHK'D								DWG NO. <h1>Stick Vice PCB</h1>			
APPVD											
MFG								SCALE:1:1			
Q.A											
						MATERIAL:		SHEET 5 OF 5			
						WEIGHT:					

6

5

4

3

2

1